

"UNPARALLELED PERFORMANCE AND SAFETY UNDER PRESSURE!" [®]

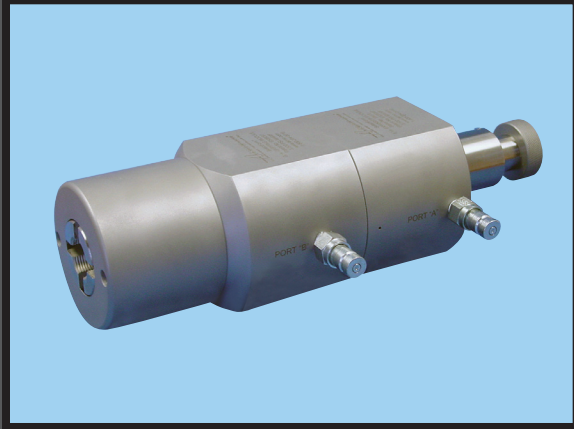

SelectForm[®]

Model M Series Modular End Forming Tools

- Pressures up to 3,000 psi (207 bar)
- 0.13 in. to 3.00 in. OD (3.2 mm to 76.2 mm OD)
- Expand, reduce, bead, or flare tube ends
- Three modular tool sizes in ram or finger style
- Precision-machined stainless steel construction
- Manufactured to customer specifications

DESCRIPTION

The patented SelectForm[®] Model M Series Modular End Forming Tool accurately expands, reduces, beads, or flares a shape on tube ends with diameters from 0.13 in. to 3.00 in. (3.2 mm to 76.2 mm). These tools are available in three sizes; and are designed to be easily interchangeable modules and tooling. When combined with the SelectForm[®] Model 400 Hydraulic Power Pack, tools can be mounted as a single-station or multi-station configuration on top of the power source.

Modular Tooling Breakdown: The modular tooling consists of two major components: the gripping and the forming modules. Mounted within each of these modules are individual sets of tooling, which can be quickly converted to different tube diameters or produce different forms.

Gripping Module: The gripping module contains a set of collets, which grips and holds the tube during the forming process. One set of collets is required for each outside tube diameter to be formed. The form shape can also affect collet requirements. For example, the collet for producing 0.63 in. (15.9 mm) beads is different from the collet for 0.63 in. (15.9 mm) flares.

Forming Modules: Two forming modules are available, each with a convenient knob to control form length. The expansion module produces an expanded tube end or bell shape. The reduction module is used to produce reductions, flares, and beads. Mounted within each of these modules is a set of forming tooling. One set of tooling is required for each specific form size and shape you expect to produce.

APPLICATION

The SelectForm[®] Model M Series End Forming Tools produce a variety of tube end forms for industrial applications used by manufacturers in: aerospace and aircraft, boiler manufacturing, heat exchanger and radiator, military, nuclear and hydroelectric, metal furniture, on/off road mobile vehicles, outdoor power equipment, plumbing fittings, sports equipment, boat and water craft, tube and pipe mills.

TOOL CONFIGURATION

Grip:	On tube OD
Actuation:	Hydraulically-operated extend and retract
Forming Type:	Hydraulic ram for most applications Finger style for beading in sizes 2 and 3 only

OPERATING CONDITIONS

Maximum Pressure:	3,000 (207 bar)
Temperature:	32° F to 120° F (0° C to 49° C)
Expansion Length:	Up to 3 x tube OD, depending on application
Expansion:	<20% of the Tube OD*
Reduction Length:	Up to 3 x tube OD, depending on application
Reduction:	<20% of the Tube OD*
Bead:	AS5131 or other specification
Flare:	37° and 45°
Wall Thickness:	Standard tubing
Materials:	Aluminum, carbon steel, copper, stainless steel, and titanium

* Actual expansion range may vary depending on material, please check with Airmo for details.

MAXIMUM PRESSURE
3,000 psi
207 bar

SelectForm®

Model M Series
Modular End Forming Tools

Model M Series
Modular End Forming Tools

Tool	Tube OD Range				Mandrel/ Die Stroke*	
	Inches		MM			
	Min.	Max.	Min.	Max.	Inches	MM
M1	0.13	1.00	3.2	25.4	1.50	38.1
M2	0.50	2.00	12.7	50.8	2.50	63.5
M3	1.50	3.00	38.1	76.2	4.13	104.8

* Note: Usable formed length is less than stroke.

COMMON END FORMS

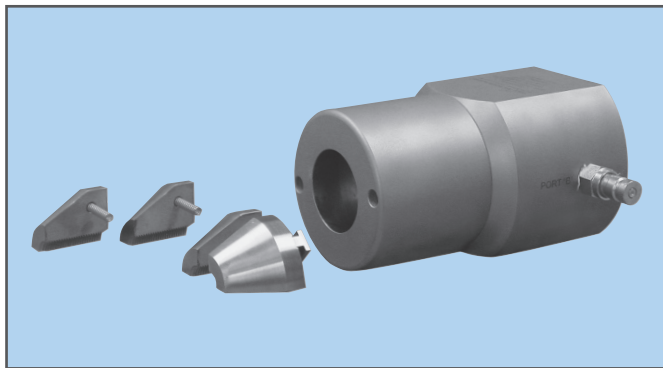
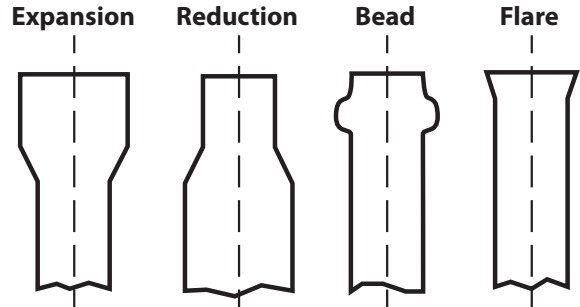

SelectForm® G1 Gripping Module Shown with Collet Set.

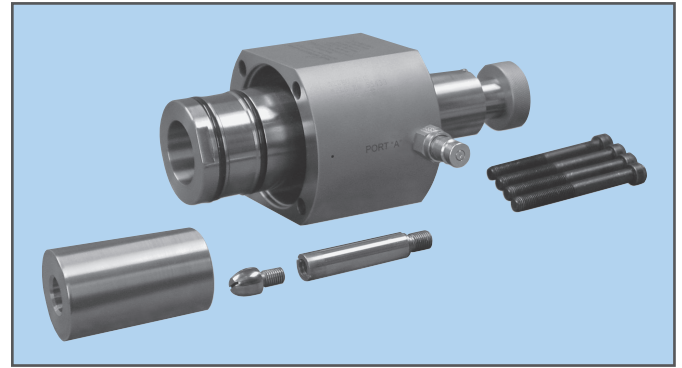

SelectForm® E1 Expansion Module Shown with Forming Tool Set.

FEATURES

- Fast operation, cycles in 7 seconds or less
- Choice of 3 modular sizes in ram or finger style
- Fast tool changeover
- Low marking collet design
- Adjustable form length control
- Compact design
- Precision-machined from heat-treated stainless steel
- Coated mandrels and dies
- Non-standard sizes
- Designed for use with SelectForm® Hydraulic Power Pack

BENEFITS

- Increases productivity and throughput
- Tube diameters from 0.13 in. to 3.00 in. (3.2 mm to 76.2 mm)
- Change tool modules in 10 minutes or less
- Prevents tube end collapse and eliminates scrap
- Fine-tune form shape to meet requirements
- Capable of end forming pre-bent tubes
- Provides long, trouble-free service
- No lubrication required for most applications
- Special configurations available upon request
- Transport portable system and tooling to job site



AIRMO, INC. 9445 Evergreen Blvd. NW, Minneapolis, MN USA 55433-5840

PHONE: (763) 786-0000 FAX: (763) 786-4622 EMAIL: airmo@airmo.com WEBSITE: www.airmo.com